

PRSR STD  
U.S. POSTAGE  
PAID  
Oelwein, IA 50662  
Permit # 81

# Fairbank ISLANDER

SERVING FAIRBANK AND THE SURROUNDING COMMUNITIES

SEPTEMBER 4, 2024 Compiled by Fairbank Community Club - Designed by Waverly Newspapers and Printed by Oelwein Publishing Co. VOLUME 5, NO. 9

# BACK TO SCHOOL

## Teachers join the Warriors



MIRA SCHMITT-CASH | OELWEIN DAILY REGISTER

Above: Teachers new to the Wapsie Valley School District this year are, from left, Emma Menzel, Emily Ross, Gunnar Rodgers and Tyler Fall. Below : Kristin Sadler will teach first grade at Fairbank Elementary this year.



MIRA SCHMITT-CASH  
news@oelweindailyregister.com

FAIRBANK — Five teachers join the Wapsie Valley School District in 2024-2025, Tyler Fall, Emma Menzel, Gunner Rodgers, Emily Ross and Kristin Sadler. New staff in-service was Aug. 15-16, and the full staff came back Aug. 19-22, per the district calendar. Class started Aug. 23.

- Fall, a recent graduate of Wartburg College, will teach vocal music in grades 7-12.
  - Former 7-12 vocal music teacher Abbie Fyfe, who directed the musicals — including while pregnant last spring — decided to be a stay-at-home mom, according to administrators.
  - Rodgers, a recent Upper Iowa University graduate, will teach health, strength and conditioning at Wapsie Valley.
  - Former health teacher Chase Weber took a job in
- See TEACHERS, A2

## Wapsie Valley headed back to school Aug. 23



The bright morning sun heralded the return to Wapsie Valley

Elementary as students and parents alike embraced the annual back-to-school celebration. The first day of school is always a momentous occasion, and this year was no exception, filled with a blend of excitement, anticipation, and a touch of nostalgia. As families arrived at the school, the atmosphere buzzed with energy. Parents walked alongside their children, many holding hands and exchanging smiles. The school building, adorned with colorful welcome banners and cheerful decorations, set the stage for a day filled with new experiences. Teachers stood at the

See SCHOOL, A2



COURTESY PHOTOS



Above left: Fourth graders are thumbs up for the new school year. Above right: Mrs. Bachman, 3rd grade teacher welcomes the group hug from returning students. Left: Front office staff, Lori Jergens, secretary, Holly Meyers, principal and Tara Sullivan, secretary are excited to begin the new year.

# A NOTE FROM THE MAYOR



MAYOR JASON KAYSER

August begins the winding down of summer activities and school beginning. City staff have begun shutting down and winterizing the pool and the police department is working on activities in the school with our School Resource Officer. The Council and department heads have compiled a list of goals and projects moving forward. Some are simple necessities,

and some are lofty visionary projects. Following the first meeting in September, we will begin prioritizing the projects in anticipation of publishing the list for public input. You are encouraged to attend the meeting to provide input as well. Public Works will be working on some street projects this fall as well. The Fire Department has taken position of Iowa's first rural rescue response unit, which they have been working on for well over a year. Our recreations programs have ended and once again we provided recreation and swimming opportunities to hundreds of children. A big thank you goes out to rec coaches, refs and umpires, managers, and lifeguards for once again stepping up to serve the youth of the area.

## Teachers join the Warriors

CONTINUED FROM A1

Jesup, per office staff.

- Ross will teach 9-12 Spanish. In her fourth year of teaching, she worked most recently for the Tripoli Schools from where she led a student trip to Costa Rica, she noted in introductions.
- Menzel will teach 5-12 instrumental music. A seventh-year teacher, she joins the Warriors from the Moulton-Udell Schools on Iowa's southern border.
- Former 5-12 band teacher Emily Redden took a job in Des Moines, administrators said.
- Kristin Sadler is new to the district and will teach first grade at Fairbank Elementary after some internal shifting of faculty. Sadler graduated from UIU.

# Wapsie Valley headed back to school Aug. 23

CONTINUED FROM A1

entrance, warmly greeting students and families, their enthusiasm evident as they welcomed everyone back to the vibrant learning community. The hallways of Wapsie Valley Elementary,

students navigated their way to their new classrooms, their faces a mix of eagerness and nervousness. For many, it was a day of reunion with friends after a long summer apart. Laughter echoed as students spotted familiar faces, joyfully exclaiming each other's names and rushing to

catch up. "I can't believe we're in fourth grade now!" exclaimed Lauren Matthias hugging her friends.

Parents, too, were filled with emotions as they prepared to send their children off for another year of learning.



Left: Wapsie Valley bus driver, Tracy Gruetzmacher. Above: 6th grade leaders did a great job sharing with students about different areas in our building. They taught us how to be safe and rules or expectations in those areas.

## CITY WIDE CLEAN UP DAY MONDAY, OCT. 7

City wide clean up day will be on Monday, October 7, 2024, at 6:00 AM. All items must be placed curbside (excluding metal).

Metal items will NOT be picked up curbside. There will be a metal dumpster located behind City Shop the week before cleanup day for metal items. Everything else will be picked up on the curb. If you have any questions, please call Kluesner Sanitation at 563-927-5977.

All appliance & electronic tags are \$20 per unit and must be purchased by 5:00 PM on Friday, October 4, 2024.

FAIRBANK COMMUNITY CLUB

### VOLUNTEERS NEEDED FOR FAIRBANK CEMETERY CLEAN UP

Contact Kenny Little for questions  
319-238-2828

**OCTOBER 5  
8:30 AM  
FAIRBANK PUBLIC CEMETERY**

FAIRBANK ISLANDER

SERVING FAIRBANK AND THE SURROUNDING COMMUNITIES

Sponsored by:  
Fairbank Community Club  
Fairbank, Iowa 50629

Mailed free of charge to everyone with a Fairbank or Oran zipcode.

**Out-Of-Area Subscriptions**

**1 Year (12 issues) . . . . . \$30.00**

Mail address and check to:  
Fairbank Islander  
301 Catherine St., Fairbank, IA 50629

\*\*\*The Fairbank Islander is also available for viewing on-line at the Fairbank Library website:  
[fairbank-ia.org/newsletters.php](http://fairbank-ia.org/newsletters.php)

E-mail News & Advertising to:  
[fairbankislander@gmail.com](mailto:fairbankislander@gmail.com)

or drop off at:  
Fairbank Public Library  
P.O. Box 426, Fairbank, IA 50629

For information, call:  
Melaine Buzynski 319-404-7116  
or the Fairbank Library 319-635-2487

## What's Cook'in

Keep your words soft and sweet; you never know when you may have to eat them!

**Fall is a good time for casseroles!**

### Mom's Chicken Casserole

2 c. cooked, diced chicken	½ lb. Velveeta or American cheese
2 c. macaroni (uncooked)	1 can cream of chicken soup
1 can cream of mushroom soup	1 onion, grated
1 soup can of milk	Salt & pepper to taste

Mix soups and milk. Combine with remaining ingredients and mix well. Let stand in refrigerator overnight or for 5 to 6 hours. Place mixture in a 9x13 inch pan. Cover with aluminum foil and bake at 350 degrees for 60-70 minutes. Tuna or ham could be used instead of the chicken.

### Zucchini Brownies

2 c. ground zucchini	2 c. flour
½ c. sugar	½ tsp. salt
½ c. vegetable oil	½ tsp. baking soda
½ c. nuts (chopped)	1/3 c. cocoa
1 tsp. vanilla	(No Eggs!)

Sift together flour, salt, baking soda and cocoa. Combine with the rest of the ingredients and stir. Transfer to a greased 9x13 inch pan. Bake at 325-350 degrees for 30 to 35 minutes or until done. Good with or without frosting!

**We need recipes to publish. If you would like to share your favorite recipes, you can drop them off at the Fairbank Library or email them to: [Fairbankislander@gmail.com](mailto:Fairbankislander@gmail.com)**

## Deadline for October publication is September 23.

Please contact Melaine at 319-404-7116

Or email [fairbankislander@gmail.com](mailto:fairbankislander@gmail.com)

Please send us your celebrations. Celebrations are free to submit.

# ANNIVERSARY



## WOODS CELEBRATE 65 YEARS

Mr. & Mrs. John Woods of Fairbank will be celebrating their 65th wedding anniversary on Sept 26th. John Woods and Sharon Lee Recker were united in marriage on September 26, 1959 at Sacred Heart Catholic Church in Oelwein.

They are the parents of Randy (Jodi), Ron (Carol), Rick (Cindy), Roxanne (Bob Jerdee) all of Fairbank and Rhonda (Scott Swanson) of Chicago, IL. They have 16 grandchildren and 12 great-grandchildren.

The couple will celebrate their anniversary with a family dinner later this month.

# BIRTHDAYS



## WISHING 3 BUZYNSKI'S A VERY HAPPY BIRTHDAY

Pete-20th, Scott- 15th and Tom - 22nd.



## HAPPY BIRTHDAY MELISSA KLENZMAN

September 15



## HAPPY BIRTHDAY BETTY BRANDT PASSICK

August 13 - 77 years



# BUILDING

OUR REPUTATION ONE CUSTOMER AT A TIME

We've been helping homeowners and contractors complete their projects with premium building materials and lumber. We pride ourselves on the quality of our product selection, as well as our commitment to value and great service.



## SEPTEMBER SPECIAL OF THE MONTH

Special of the MONTH

While Supplies Last!  
**9.99**

8' x 10' Medium-Duty Poly Tarp



When it comes to your next project, come to us!



# MODERN BUILDING PRODUCTS

511 4TH STREET, HWY. V68 NORTH • FAIRBANK • 319-635-2355

Hours: Monday-Friday 7:00 to 5:00 • Saturday: 7:00 to Noon • www.modernbuildingproductsia.com



# 4-H ATOM BOMBERS



FROM THE DESK OF  
**ALIVIA WEEPIE**

Meat?) and Ashley Brennan (Warming a Chilled Kid).

Bills submitted for new barn signs and the meeting decorations for fair booth. Went over the cost and profit of chicken dinner fundraiser that was held during Fairbank Days.

Record books are due at the September 8 meeting, worksheets can be found on the 4-H website. Membership enrollment for the new 4-H year is now open, please make sure to sign up. Election of new officers will be held at the September meeting.

Big thank you to Landon by Kane for providing a tour of the Red Rock Farm. Everyone enjoyed learning more about the animals on the farm and of course cuddling with the puppies. The club will be volunteering at the farm in October. Look for more information to come.

Next meeting September 8 at the 5:00 pm at IC Hall.

Hosts: Kelly's, Guest speaker - Bread making

The August meeting of the Atom Bomber 4-H club was held at Red Rock Farm on July 18.

Kenley Happel acted as president due to absentee of officers. 18 members and guests were present.

Roll call question what was "What was your favorite part of fair or your favorite part of summer?" 4-H pledge led by Riya Kelly.

Presentations by Clover kids Jake Brennan (Why Goat



COURTESY PHOTOS

Atom Bomber 4-H club touring Red Rock Farm. Learning about animals on the farm and getting cuddles from some puppies.



**BOOK YOUR OUTDOOR ADVENTURE TODAY!**

1080 102nd St  
Fairbank, IA 50629  
Call or text: 319-404-6475  
Email: ajscamperrentals@gmail.com  
Website: ajscamperrentals.com



**Woods Funeral Home**  
*Our family serving your family, since 1959*  
 400 Lakeside Drive Fairbank  
**319-635-2207**

## Celebration of Life

### Donna Mae Geary

July 25, 1934- August 10, 2024

Donna Mae Geary age 90 of Cedar Falls and formerly of Fairbank, died on Saturday, August 10, 2024 at the Western Home Communities where she resided the last few years of her life.

Donna was born on July 25, 1934 to Ralph and Pauline (Sagert) Reinard in Raymond, Iowa. Donna's grandparents, William and Emma (Kurt) Sagert, were also instrumental figures in her childhood. On June 18, 1952, Donna married Robert (Bob) Geary. Donna and Bob would live in Waterloo until 1970, where she worked in the bakery of the SunMart grocery store near their home. Following their move to an acreage outside of Fairbank, she served bravely as a bus driver for the Wapsie Valley Community School District for nearly 30 years.

Donna and family lost Bob to cancer in 2001. After realizing she needed new inspiration in her life, she rededicated a portion of their acreage which Bob, a pilot, had previously used as a landing strip; the land would become a place where she could express herself through her love of flowers and antique art. "You've got to take an interest in something. There's no point in dwelling on what could have been. This is now," Donna shared when interviewed by The Waterloo-Cedar Falls Courier on the land's transformation following Bob's death. Donna would become known for her beautiful flower gardens, and enjoyed when passersby would stop to admire her work, often offering them a cup of coffee and a tour.

In addition to her love of gardening and antiques, Donna was an aficionado of all things fiber art; she was a master of crochet, knitting, and cross-stitch. Her memory lives on in the numerous afghans, cross-stitch tapestries, and transplanted perennials bestowed upon her loved ones. We'd like to think that Donna is already busy sewing some beautiful new projects in Heaven.

Above all else, Donna's greatest loves were her children and grandchildren. She concluded every visit by telling them she loved them, and then planting multiple kisses on their cheeks.

Donna is survived by sons Tom (Joyce) Geary of Denver, Iowa and Steven (Jolene) Geary of Bristol, Wisconsin, daughter Chris (Garry) Meier of Oran, and daughter-in-law Marie Jo Geary of Des Moines; five grandchildren: Andrea Geary (Steven Swanson), Wade Geary, Jeremiah Geary (Jamie Voshell), Brittany (Nick) Cripps, and Brandon Geary; five step-grandchildren: Gina (Karl) Ekstam, Michael (Paige) Kossack, Joe Meier, Ben Meier, and Michele Lawrence; seven great-grandchildren: Mila, Michael, Jai, Xavier, Keynan, Analisa, and Uriah; and 17 step-great grandchildren.

She was preceded in death by her parents, Ralph and Pauline; her husband, Bob; her son, Michael; her sister, Carolyn Olmstead; her brother, Roland Reinard; and her step-grandchild, Lisa Rowen.

A heartfelt thank you to the special angels at The Martin Suites and Cedar Valley Hospice who went above and beyond to help make Donna's transition as peaceful and pain-free as possible.

Donna will be laid to rest by her immediate family in a private graveside service at a later date. Memorials may be directed to Cedar Valley Hospice. Alternatively, you could consider rededicating a patch of land near you to native perennial plantings. Donna would love it.



## Celebration of Life

### Dennis Roger Farrington

June 13, 1946 - August 7, 2024

Dennis Roger Farrington age 78 of Fairbank passed away Wednesday, August 7, 2024 at St Luke's Hospital in Cedar Rapids. He was born June 13, 1946 in Oelwein the son of James and Lisetta (Tiedt) Farrington. Denny first attended

Sacred Heart School and then Oelwein Community School where he graduated from. After high school he was employed at John Deere in Waterloo for the next 30 years retiring in 1996, starting out first in the foundry and then the component works on Westfield. Denny married Paula Siggelkov on May 6, 1967 in Fairbank at the Immaculate Conception Catholic Church. They made their home in Fairbank where they raised their four daughters as well as being foster parents for 15 children over a span of 13 years. After his retirement, Denny spent much of his time wood working. He was quite a craftsman, making rocking chairs and cradles for his daughters along with many other creations. He also worked for many years with his good friend, Mark Owens, and his company, American Tradition which was originally located right across the road from his house. Denny continued to work with Mark even after he moved his shop to his farm north of Fairbank with one condition: on the days that Mark needed him, he would have to come to Fairbank and pick him up. Denny's family is not sure how much work got done, but he enjoyed it so much that he worked right up until December of last year when he became ill. Denny was a longtime member of Immaculate Conception Church, charter member of the Fairbank Knights of Columbus, and a charter member of the Fairbank Jaycees. He enjoyed spending time with his family whether it be the holidays or the grandchildren's school activities. Denny and Paula also enjoyed taking chartered bus trips to many different destinations. What mattered most to Denny was his family, especially his grandchildren. He really loved being grandpa. He loved doing card tricks and of course his famous disappearing penny trick. Denny is survived by his wife, Paula, four daughters; Sheila Farrington of LaPorte City, Janece (Armando) Silva of Fairbank, Stephanie (Joe) Ahles of Waterloo and Jill (Josh) Zbornik of Independence, nine grandchildren; Armando Jr., Malena, Emma and Nollynn Silva, Jessica and Joey Ahles, Austyn, Alayna and Addisyn Zbornik, and one bonus grandson, Abe Silva. He is also survived by one brother, Mike (Elaine) Farrington and two sisters; Veronica (Tom) Roth and Virginia (Harv) Curry along with many nieces and nephews. He was preceded in death by his parents, one sister and brother-in-law, JoAnn and Al Everman, three sisters-in-law and two brothers-in-law; Maxine and Jack Dempsey, Marion Siggelkov, Sister Julie Siggelkov and Fred Siggelkov; three nephews; Butch Everman, Rick Curry, Scott Dempsey and three nieces; Kim Mason, Kelly Everman and Tracy Cox.

Visitation took place: 3:00-6:00 PM Sunday, August 11, 2024 with Knights of Columbus Rosary at 2:30 PM at Woods Funeral Home.

Funeral Mass took place: 10:30 AM Monday, August 12, 2024 at Immaculate Conception Catholic Church, Fairbank

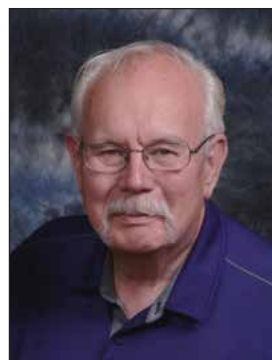

## Celebration of Life

### Dorlin James "DJ" Moeller

January 14, 1937 - July 10, 2024

Dorlin James "DJ" Moeller age 87 of Fairbank passed away Wednesday, July 10, 2024 at Unity Point Allen Memorial Hospital in Waterloo. Dorlin was born January 14, 1937 in rural Bremer county the son of Herman and Lydia (Matthias)

Moeller. He grew up on the family farm in rural Fairbank, he attended and graduated from the Oran School. After high school he received his Bachelors Degree in Education at Wartburg College in Waverly. Dorlin began his teaching career in the Allison-Bristow School district and then the Wapsie Valley Community School district, retiring in 1997, altogether he taught mathematics for a total of 38 years. He was greatly appreciated for his many years of teaching and was known for his patient but firm method of instruction. After retirement Dorlin did a little farming because he always enjoyed life on the farm. He enjoyed watching sports on television, he was an avid Pittsburg Pirates fan as well as the Iowa Hawkeyes and of course the Wartburg Knights. He loved the game of Cribbage and used it as a teaching tool, as a matter of fact it was pretty much a requirement for his many nieces and nephews to learn to play it. Dorlin spent a number of years living at Mercy Living Plus in Oelwein and considered the staff and many of the other residents as part of his family, he truly enjoyed living there. He is survived by his brother, Ron (Dianna) Moeller and his sister, Lois (Jerry) Heineman, a sister-in-law, Marlene Moeller along with 32 nieces and nephews. He was preceded in death by his parents, two sisters; Verla Kane and Darlene Tiedt, two brothers; Leon and Kenneth Moeller, two brothers-in-law; Ralph Kane and Earl Tiedt, one sister-in-law, Betty Moeller, one niece, Tracy Heineman and one nephew, Greg Moeller.

Funeral Services took place: 10:30 am Saturday, July 13, 2024 with visitation from 9:00-10:30 am at St. John's Lutheran Church, Fairbank.



Pray for our nation  
Pray for our world  
Everyone is invited to  
join us in a public  
rosary to be held in  
the Mary prayer  
garden at Immaculate  
Conception Church  
Fairbank, September  
13th starting at 5 PM



# Celebration of Life

## Mary Louise Peters

February 28, 2024

Mary Louise Peters (Carroll, Dimmich) age 76 of Fairbank passed away on February 28, 2024 in Orlando, Fla. at the home of her daughter Jana. She was surrounded by her loved ones including one of her dearest friends Mary Jans of Fairbank.



Mary Lou as many called her was the daughter of the late Louie & Clara Peters. She worked at Immaculate Conception Catholic Church in Fairbank for several years as church secretary. Mary graduated from IC High School in 1965 as Fairbank was her hometown. She was witty, independent and a social gal who always lived her life on her own terms. She loved to dance, bake and read and had a knack for home decor.

She was devoted to her family and leaves behind five children: Thomas (Michelle) Carroll of San Jose, Calif., Christie (TJ) Hunter of Phoenix, Ariz., Jana (Brian) Spence of Orlando, Fla., Jeremy (Krista) Carroll of San Carlos, Calif., Jeffrey (Jenna) Carroll of Sebastian, Fla. and she is survived by eleven grandchildren.

There will be a Mass in her name at the IC Catholic Church Fairbank on September 1st at 8:30 AM. Afterwards the family will proceed to the IC Cemetery. Mary Lou's children would like to thank all of her Fairbank friends for making her life so rich. She loved you all very much.

# Celebration of Life

## Jennifer Marie Cindrich

April 14, 1972 – August 11, 2024

Jennifer Marie Cindrich, 52, passed away peacefully surrounded by family at Unity Point in Waterloo, in the early morning hours of Sunday, Aug. 11.

Jennifer was born on April 14, 1972, in Oelwein, the daughter of Charles "Bob" and Linda (Ludden) McCarty. She was a graduate of Oelwein High School and went on to receive her nursing degree from Hawkeye Community College.

She was united in marriage to her husband, John Cindrich on Feb. 4, 1994. They raised two daughters, Spencer and Sydney, in Fairbank.

Jen was survived by her husband, John; her daughters, Spencer (Craig) Sperfslage and Sydney (Hunter) Churchill; three grandchildren; her mom, Linda McCarty; her sister, Samantha (Daniel) Power; and her mother-in-law, Ann Sparks; her aunt, Cindy Nicolay and nieces and a nephew whom she loved dearly.

Preceding her in death was her father, Charles "Bob" McCarty, a brother, Charles Robert McCarty, Jr., and her father-in-law, John Cindrich.

Jennifer would have hated the idea of a memorial service where attention was all on her. The family will be celebrating her life at the later date in private but invites anyone to please privately celebrate Jen's memory in your own ways. We know that she will be with us all in spirit. Thank you for your understanding during this difficult time.

# Celebration of Life

## Marilyn L. Schmitt

July 27, 1944 - August 9, 2024

Marilyn L. Schmitt, 80, of Waterloo, formerly of Fairbank, died Friday, Aug. 9 at her home after a lengthy illness.



She was born July 27, 1944 in Mayville, Minn., daughter of Victor and Ethel Paris Marquardt. She graduated from Waterloo East High in 1962.

Marilyn was united in marriage to Norman R Schmitt "Butch" on Sept. 28, 1963 at St. Joseph Catholic Church, Waterloo. She and her husband raised their family and farmed in the Fairbank area. After her children graduated, she went to work at John Deere Health and H & R Block.

Marilyn's passion was spending time with her family, enjoying camping trips and snowmobiling with them. She and Norman enjoyed traveling and riding his motorcycle. They shared their love of travel by visiting 48 states together. In her quiet times, Marilyn enjoyed reading.

She is survived by: her husband; two daughters, Madonna (John) Hoth of Ely, Iowa and Michelle (Ray) Kessenich of Cape Coral, Florida; a son, Rodney (Patty) Schmitt of Spring Hill, Tenn.; 8 grandchildren, Megan (Kevin) Kaiser, Lauren Hoth, Cory (Stef) Schmitt, Austin Hoth, Justin, Jared, Jason and Jacksen Snitselaar; 4 great-grandchildren, Avery, Olivia, Karson and Evelyn; two brothers, Verlyn (Regina) Marquardt and Morris (Linda) Dolph of Waterloo; one sister; two sisters-in-law, Lucy (Keith) Wiebbeke of Fairbank and Berniece "Butch" Marquardt of Evansdale; and several nieces and nephews.

Preceded in death by: a son, Paul Schmitt; a daughter-in-law, Lori Schmitt; two brothers, Stanley and Verdale Marquardt; her mother and step-father, Ethel and Morris Dolph; and in-laws, Mary and Roger Schmitt.

Mass of Christian Burial took place on Saturday, Aug. 17 at Immaculate Conception of the Blessed Virgin Mary Catholic Church with burial in Immaculate Conception Cemetery, both in Fairbank. Memorials may be directed to Cedar Valley Hospice or St. Jude Children's Hospital.

Online condolences may be left at [www.hagartywaychoffgrarup.com](http://www.hagartywaychoffgrarup.com).

# Shrine of Our Lady of Guadalupe bus trip

Sponsored by Faith Formation Committee, Immaculate Conception, Fairbank, Iowa



Come join us on a bus trip to the Shrine of Our Lady of Guadalupe in La Crosse, Wisconsin

**WHEN: Tuesday, September 24, 2024**

**WHERE/WHAT: Shrine of Our Lady of Guadalupe in La Crosse, Wisconsin**

Trip includes a guided tour of the shrine church, visit to the outdoor devotional areas and gardens, and Mass. Lunch is available for an additional charge. Stop at Toppling Goliath Brewing Company in Decorah on the return trip (additional charge for food and drink)

Reserve your seat by calling Glenda at 319-635-2211

All are welcome, Leaving IC HALL at 7:30 a.m. Cost is \$50.00 per person (includes transportation only)

## K C's PANCAKE

### BREAKFAST

SUNDAY, OCT 6

9:00AM – NOON

Immaculate Conception Parish Hall, Dine-in or Carry-out

'ALL-YOU-CAN-EAT'



PANCAKES



with sausage links, eggs, toast, fruit, coffee, milk, and juice

Free Will Offering/All proceeds go to Readlyn Fire Department

Sponsored by IC Knights of Columbus



COME JOIN US FOR

# COFFEE DONUTS & FELLOWSHIP

SEPTEMBER 15

Hosted by FFCOM

OCTOBER 13

Hosted by 4th and 5th Grades

OCTOBER 27

Hosted by FFCOM

IMMACULATE CONCEPTION HALL  
9:30am-11:30am

EVERYONE WELCOME  
FREE WILL OFFERING



# Immaculate Conception Parish monthly community potluck

The Immaculate Conception Parish would like to extend a personal invitation to all Fairbank residents to join us for our monthly Community Potluck at the IC Church Hall. This social event is sponsored by the IC Parish Life Committee and held at 11:30 on the third Wednesday of each month. We

ask that guests bring their favorite dish to share as they gather for lunch and fellowship with friends and neighbors. The September Potluck will be held on Wednesday, September 18th at 11:30. We hope you will mark your calendars and plan to join us.



We enjoy welcoming these ladies each month. Starting at the bottom left is Verna Kerns, Gerry Johnson, Loyola Kleitsch, Lorraine Corcoran, Arnola Siggelkow, Anna Mae Wolfgram, and Wilma Welsh. Seated to the right of these ladies are our special friends from Parkview that join us each month.



Above left: Parish Life members look forward to the monthly gatherings as well. From the left are Bob Byersdorfer, Mary Ann Kleitsch, Mary Jane Woods, Susan Shannon, and Diane Shields. Above right: We always enjoy a wide variety of hot dishes, salads and delicious desserts. No one goes home hungry!

## Church + Services



**United Methodist Church**  
107 N. 2<sup>nd</sup> Street  
Fairbank, Iowa 50629  
319-635-2932  
Worship Service: 9:15 AM



**St. John Lutheran Church**  
(MISSOURI SYNOD)  
208 N. 4<sup>th</sup> Street  
Fairbank, Iowa 50629  
319-635-2181  
Worship Service: 10:30 AM



**Immaculate Conception Catholic Church**  
302 W. Main Street  
Fairbank, Iowa  
319-635-2211  
**Father Ray Atwood**  
Sunday Mass: 8:30 AM  
Wednesday Mass: 8:30 AM  
1<sup>st</sup> Saturday Mass: 8:30 AM

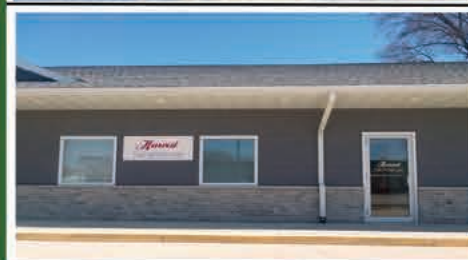

**Lord of the Harvest**  
Prayer and Praise Center  
101 South 4th Street  
Fairbank, Iowa 50629  
Saturday Night 7:00 PM  
Sunday Service: 9:00 AM  
Worship Service: 9:00 AM



**First Baptist Church**  
304 Grove Street  
Fairbank, Iowa 50629  
**Rev. Mike Anderson**  
Worship Service: 9:00 AM  
Sunday School: 10:00 AM

**#3 Ag Lender in Iowa\***  
**Top 50 Ag Lender in the Nation\***  
\* Source: Top 100 Farm Lenders Ranked by Dollar Volume, FDIC, Data as of 4Q 2021.

**Adam Schaufenbuel**  
Vice President, Waverly

**Megan Niewoehner**  
Loan Officer, Oelwein

www.bankfidelity.bank | 800.403.8333

**Balance Made Easy.**  
*Balance your retirement goals with your life insurance needs with The Balanced Program from Ozark National Life. You may even qualify for substantial tax savings with a Roth IRA. Let me show you how!*

**Joe Kleitsch**  
Home: 319-635-2297  
Cell: 319-269-1443  
joseph.kleitsch@ozark-national.com

Wholly Owned Subsidiaries of National Western Life Group, Inc.

**Parkview Assisted Living**  
114 Forest St  
FAIRBANK, IA.

*Caring for Our Family, One Loving Heart at a Time*  
Contact us at 319-635-2585  
Stop in anytime for a tour  
Check us out on Facebook or our website:  
[fairbankparkviewassistedliving.com](http://fairbankparkviewassistedliving.com)  
*We'd Love to Welcome Your Loved One HOME!*

\* 2 Daily Homemade Meals  
\* Weekly Housekeeping & Linen Washing  
\* Emergency On-Call System  
\* 24-Hour Security and Staff Availability  
\* Utilities and Cable Included  
\* Secure P.O. Box Included

Located directly across from Island Park, along the Little Wapsie River

**FAIRBANK**  
Plumbing & Heating, Inc.

Brad, Adam & Ben Bachman  
**641-330-1233      319-635-2229**  
**THANK YOU FOR YOUR BUSINESS!**

# Former students attend Fairbank's all school reunion

About 75 former students attended the Fairbank All School Reunion on August 3rd at the American Legion. All former students and staff of Fairbank High School, I. C. Catholic School, St. John's Lutheran School, and Wapsie Valley High School were welcome to attend. Admission was \$10.00, collected at the door by Maurice and Wilma Welsh. Maurice taught math and social studies in the Wapsie Valley School System, retiring in 1993 after a 46-year career.

The event began at 4 pm with a social hour. Fairbank Food Center provided pulled pork sandwiches, beans, and cookies for dinner.

Bob Shields, FHS president, presented a dozen small prizes to the person with the most children, grandchildren, etc. Morris Welsh won almost every prize.

Betty Brandt Passick photographed many of the attendees.

Jason Kayser and Mick Staebell provided the music of "Busy Fingers, Dueling Pianos" at 7 pm.

The reunion is sponsored by the Fairbank Historical Society, Fairbank American Legion, and Fairbank Food Center.



**Oran Fire Department**

# Annual Steak Fry

**September 14**

**5 PM- 8 PM**

**Oran Fire Department**

16oz Ribeyes  
Chicken Breasts  
Cheesy Potatoes  
Corn  
Dinner Rolls  
Drinks

**Ribeye \$25**  
**Chicken Breast \$15**

All proceeds go towards new equipment, training, and gear. Steaks Processed by Oran Locker

**WAPSIE VALLEY WARRIORS**

# Homecoming Tailgate

CELEBRATE TRADITION AND SCHOOL SPIRIT BEFORE THE HOMECOMING GAME

Friday, October 4th, 2024  
5:00pm - 7:00pm

Located Behind the High School

All Wapsie Warrior Fans Are Invited!

**Immaculate Conception - Fairbank**

## Fall Dinner

**SUNDAY, October 20**

IC Church Mass 10:00AM  
Serving 11:00 AM - 2:00 PM

Roast Beef, Ham  
Mashed Potatoes, Gravy, Baked Beans,  
Coleslaw, Rolls, + Beverages  
Soft Serve Ice Cream + Dessert

Adults: \$15 Ages 5-11: \$7  
4 & under Free Carry Outs Available

Raffle tickets- \$5.00 ea.  
Sold before & during event  
Top Prize \$500 & (5) \$100 Prizes  
Drawing at 2PM!  
Need not be present to win!!

**Bake Sale**  
Pies, Cookies, Cakes, Breads, Jams and Jellies, Salsas, Canned goods  
Please join us!!!

**YOUR Independent Insurance AGENT**  
'SERVES YOU FIRST'

**INSURANCE HEADQUARTERS INC.**  
**VANDAELE INSURANCE, LLC**

**GRINNELL MUTUAL**

[greatrates@vandaeleins.com](mailto:greatrates@vandaeleins.com)

## For all your insurance needs!

**Farm \* Home \* Auto \* Commercial**  
**Crop \* Health \* Life Insurance**

119 E. Main Street • PO Box 467 • Fairbank, IA 50629  
**319-635-2526** Fax: 319-635-2162

**LITTLEWAPSIE COMMUNICATIONS**

Visit [www.littlewapsie.com](http://www.littlewapsie.com) to subscribe today!

**The kids are back in school and perhaps it's time to give your Internet provider an A+ upgrade!**

**School is back in session**



# SPORTS & RECREATION

## Wapsie Valley Football



GIDAL KAISER | OELWEIN DAILY REGISTER

The 2024 Wapsie Valley football team is, in alphabetical order: Chase Ackerman, Cooper Adair, Bryar Bellis, Ethan Biretz, Zach Boevers, Griffin Brown, Reyce Burgart, Hunter Curley, Brayden Dana, Cayden Dana, Kanen Decker, Jonah Frost, Jayden Griese, Gavin Henry, Caleb Hogan, TJ Joecken, Carter Kaufman, Wally Kaufman, Kyle Knight, Josh Leistikow, Garrett Miller, Greysen Miller, Landen Moulds, Jack Munk, Aidan Oldfather, Luke Riordan, Hayden Ryherd, Carver Schares, Caleb Schneider, Tyler Schoer, James Seemann, Lane Shores, Andrew Tiedt, Dallas Tisue and Krayton Zimmerman. The cheerleading team is, in alphabetical order: Ava Auel, Mikayla Bixeman, Callie Collins, Raydyn Fink, Gwen Forsyth, Addilyn Fuller, Carly Gray, Allie Happel, Maren Jones, Landry Kane, Addisyn McElhose, Norah Oldfather and Kylie Strottman. Head coach is Jenni Gross. The football coaching staff is: Head coach is Duane Foster. Assistant coaches are Cody Jones, Ben Hogan, Joey Rigdon, Kobe Risse, Zane Sittig and Chase Weber.

**BY GIDAL KAISER**

sports@oelweindailyregister.com

For your information

Head coach: Duane Foster (Fourth season, 24-8)

2023: 9-2 (6-0 A District 3)

2023 postseason: 2-1, A quarterfinalist

Key returnees: Chase Ackerman (Sr., RB/LB; 22.5 tackles, FR, INT), Hunter Curley (Jr., RB/S; 291 rush

yards, 1 TD, 71 receiving yards; 17.5 tackles, 2 FR, two INT), Kanen Decker (Sr., QB/DB; 573 pass yards, 5 TD, 670 rush yards, 15 TD; 50.5 tackles), Josh Leistikow (Jr., RB/DB; 7 rush yards; 31.5 tackles, 2 sacks, FR, 2 INT), Garrett Miller (Sr., RB/LB; 300 rush yards, 4 TD; 25 tackles), Dallas Tisue (Sr., RB/DB; 129 rush yards, 2 TD; 20.5 tackles, FR, 4 INT)

Newcomers: Bryar Bellis (13 receiving yards), Cadyn Dana, Jonah Frost

(Sr., OL/DL; 11.5 tackles, FR), Blake Hesse (Jr., OL/DL; 0.5 tackles), Carter Kaufman (Jr., OL/DL; 10 tackles), Andrew Matthias (Jr., OL/DL; a tackle), Weston Schares (Sr., 17 receiving yards; 1.5 tackles), Andrew Tiedt (Jr., OL/DL; 44 tackles, INT)

**What They're Saying**

"Our team has made significant progress in the weight room this summer, and we have made a very tight bond between us. I can't wait till Week

1." — Hunter Curley

"I agree with Hunter, we have a really tight bond. We might not have the biggest guys on the field ... but we will have the most heart for the sport and the love for the guy next to you. We will all give 110% effort every second on the field and off the field and that is what makes this team so special." — Dallas Tisue



**Lew Boehme**  
319-415-5547

**Mitch Coffin**  
319-415-2472



**319-279-3893**  
**319-267-2035**

securitymutualins.com

234 Main Street ~ Readlyn, IA

# SPORTS & RECREATION

## Wapsie Valley Volleyball



GIDAL KAISER | OELWEIN DAILY REGISTER

The 2024 Wapsie Valley football volleyball team is, from left: Front row, Kiana Hilsenbeck (manager), Brinley Schellhorn (manager), Hailey Wehling, Peyton Curley, Natalie Gray, Bella Buck (manager), and Mykel Moothart. Second row, Whitney Destival, Claire O'Donnell, Taylor Buhr, Kennedy Kane, Kylee Moulds, Avery Jones, Kiley Schmitz, Kalle Voy, and Maddie Ladeburg. Third row, Peyton Parker (assistant coach), Brittany Anderson (assistant coach), Sadie Hogan, Lexi Brunscheon, Bailey Murphy, Tessa Brunscheon, Taylor Schneider, Maleena Sander, Laurianna Rochette, Sawyer Buhr and Austin Shepherd (head coach).

**BY GIDAL KAISER**  
sports@oelweindailyregister.com

For your information

Head coach: Austin Shepherd (Fourth season, 94-36)

2023: 28-19 (2-2 North Iowa Cedar League East)

2023 postseason: 2-1, 2A regional championship match

Key returnees: Taylor Buhr (Jr., OH, 370 kills, 289 digs, 43 aces), Peyton Curley (Sr., libero, 379 digs, 67 assists, 36 aces), Avery Jones (Sr., S, 1,059 assists, 236 digs, 39 aces, 10 blocks), Kylee Moulds (Sr., MH, 168 kills, 37 blocks), Taylor Schneider (Soph., RS, 148 kills, 41 blocks), Kalle Voy (Jr., DS,

112 digs, 13 aces), Hailey Wehling (Sr., DS, 52 digs, 17 aces)

Newcomers: Natalie Gray (Sr., DS), Kennedy Kane (Sr., MB/RS), Maddie Ladeburg (Jr., OH), Claire O'Donnell (Jr., MB/RS), Kiley Schmitz (Jr., DS)

Strengths and weaknesses

"May returners were first-year varsity starters. We return a lot of experience. We have a well-balanced offense and continue to be a strong/aggressive serving team racking up aces and putting teams out of system. We have three new hitters that will be starters and are adjusting well to the pace of the game."

"We're still learning to stay dominant the entire set and not to let off the

gas."—Coach Austin Shepherd

Expectations for the season

"Expectations for the season are to win the NICL-East Conference, place in the Top 3 of the NICL Conference Tournament, and have 30+ wins this season." —Coach Shepherd

What They're Saying

"I'm super excited for this season. I feel we have a very strong program and a lot of returners coming back this year. We're all very close and can do great things this season." — Avery Jones

"I am also super thrilled for what this season may bring. As Avery said, we have many of the same faces from last year, and so much potential

throughout the team." — Taylor Buhr

"I am also so excited for this season. I think it helps how well we get along with each other on and off the court which makes us play well together."

— Peyton Curley

"I think this season will be a lot of fun. The team has a lot of potential since we always work hard. I know the hard work will pay off and everyone will support each other the whole way." — Natalie Gray

"I am looking forward to this season and I think having that background of playing together over the past few years will benefit us. I can't wait for the season to start and have fun with our team." — Kennedy Kane

**2024-2025**

## WAPSIE VALLEY BLOOD DRIVES

**WEDNESDAY, NOVEMBER 13TH**  
1:30pm - 6:30pm  
Multipurpose room, HS

**FRIDAY, FEBRUARY 28TH**  
1:30pm - 6:30pm  
Multipurpose room, HS

**FRIDAY, APRIL 25TH**  
1:30pm - 6:30pm  
Multipurpose room, HS

**Proudly Hosted by Wapsie Valley FCCLA**

PEOPLE LIVE WHEN PEOPLE GIVE

FAIRBANK COMMUNITY CLUB

# MEMBERSHIP \$30

VENMO CODE

venmo

OR

MAIL TO:  
COMMUNITY CLUB  
C/O JEAN BELLIS  
P.O. BOX 526  
FAIRBANK, IOWA 50629

Want To Get Involved?

- ◆ volunteer for events
- ◆ join us for meetings
  - ➔ 3rd Wednesday
  - ➔ January, March, May, July, September, & November
- ◆ sponsor an event

# SPORTS & RECREATION

## Wapsie Valley's historic baseball season earns all-district recognition



BY GIDAL KAISER | SPORTS@OELWEINDAILYREGISTER.COM

Wapsie Valley's senior quartet from left, Manny Huebner, Traeton Sauerbrei, Tucker Ladeburg and Jacob Schoer was named to the IHSBCA All-Northeast District team.

### A half dozen Warriors named to 1A northeast district team

BY GIDAL KAISER

SPORTS@OELWEINDAILYREGISTER.COM

Forty games.

Thirty-two victories.

Wapsie Valley's historic season closed with a substate championship game appearance and plenty of accolades from the Iowa High School Baseball Coaches Association.

Three seniors were named to the Class 1A All-Northeast District first team, with three other players named to the second team.

Traeton Sauerbrei was named first-team pitcher, with Jacob Schoer selected first-team outfielder and Tucker Ladeburg selected to a first-team utility spot.

Sauerbrei went 9-1 in 10 starts, with a 2.10 earned-run average in 50 innings. He struck out 59 in his return to the program after a season off.

Ladeburg went 4-1 with three saves and a 1.94 ERA in 43 1/3 innings in his

final season before playing at Wartburg. He struck out 60. Ladeburg batted .421 (51 for 121) with a team-high 53 runs batted in, 30 runs scored, 21 walks and a team-best five home runs.

He was named first team utility last season, as well.

Schoer, a Simpson College commit, batted a team-best .444 (55 for 124). He drove in 52, scored 39 runs, stole 20 bases and drew 20 walks.

"Being named first team all-district is always a good thing," said Schoer, who was second team all-district last season. "This just shows the amount of success each of our teammates had individually made our team that much more successful. I will always remember the memories and success this team brought into my life."

Bryar Bellis (outfielder), Hunter Curley (pitcher) and Manny Huebner (second baseman) were selected to the second team.

Bellis batted .366 (45 for 123). He scored 51 runs, stole 30 bases, walked 28 times, drove in 25 and hit a team-high four triples.

"Being named second team is a

pretty good feeling, but I think it shows a lot of the great leadership and the roles our seniors played. All of them were on this list and I can't thank them enough for what they have done for me and our team," Bellis said.

Curley went 7-2 in 12 appearances, with eight starts, through 50 1/3 innings. He posted a 2.09 ERA and struck out a team-best 75.

"Being named second team all-district is a pretty cool accomplishment but, more importantly, if you look at the amount of us who made first or second team is impressive and shows the talent we had on this team and how special we were," Curley said.

Huebner hit .333 (37 for 111) with 25 runs, 22 RBI, 18 walks, 12 doubles and 11 stolen bases.

"Having this amount of people first or second team all-district really says a lot about our team," Huebner said. "Our whole team was great this year, everyone was willing to listen and get better. I will miss this team and all the memories we made."



Wapsie Valley's Bryar Bellis was named 2A all-district second team.



Wapsie Valley's Hunter Curley was named 2A all-district second team.

**WCI Trucking LLC**  
Connor & Randy Woods  
Ph. 319-231-2805

## Gavin Marine

*Sales ~ Service ~ Parts*

Large inventory of parts  
to get you back on the water!

*We handle your insurance claims for you!*

TOM HYDE  
GavinMarine.com  
gavinmarine@windstream.net

319-231-8242  
101 Industrial Drive  
Fairbank, IA 50629

It's your future. Let's protect it.

**Chris Boehme**  
Crop and Farm Specialist  
The Osborne Agency

1400 First St West  
Independence, IA  
319.334.9274 Office  
319.231.2415 Cell

Auto - Home - Life - Annuities - Business - Farm & Ranch - Crop

# Guidelines for Grain Bin Safety

## Thinking about building a grain bin?

If you're planning to build or move a grain bin, either on your property or for someone else, you need to be familiar with Iowa's law on required distances from overhead electric lines. This law was put in place to provide protection from the hazard of contacting overhead electric lines to anyone working around grain bins with augers, elevators, or other equipment.

The drawings inside this brochure show the specific clearance requirements related to permanently installed augers and portable augers. There must be at least 18 feet between the top of any grain bin and any overhead electric lines. These distances were developed by the American National Standards Institute. Figure 232.4(b) can be found in the 2017 Edition National Electrical Safety Code (NESC). As your electric service provider, we're responsible for ensuring that these specifications are met. In fact, in any situation where minimum clearance requirements are not observed, the utility may refuse electric service.

So if a new grain bin is on your list of projects, please give us a call. We will work with you in developing a site plan for your project.

## Grain Bin Clearance Guidelines

Source: The 2017 Edition National Electrical Safety Code (NESC) and the American National Standards Institute (ANSI C2-2017).

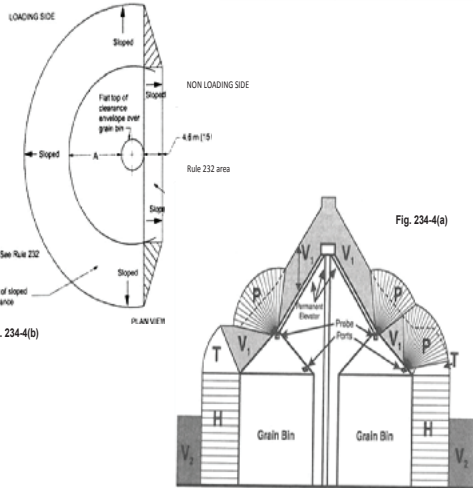
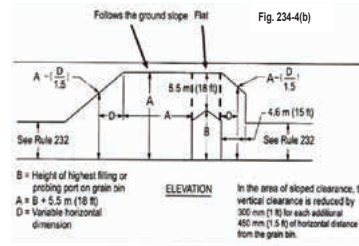

Fig. 234-4(a) -- Clearance Envelope for Grain Bins Filled by Permanently Installed Augers, Conveyors, or Elevators

P = probe clearance 5.5m (18 ft.)  
 H = horizontal clearance 4.6m (15 ft.)  
 T = transition clearance  
 V1 = vertical clearance above a building required by Rule 234C (Table 234-1)  
 V2 = vertical clearance above land required by Rule 232B (Table 232-1 or 232-2)

Figs. 234-4(b) Clearance Envelope for Grain Bins Filled by Portable Augers, Conveyors, or Elevators

### We're your partner in farm safety.

At work or at play, stay safe outdoors when electricity is around. Here are some tips:

- Keep clear of power lines.
  - When working beneath power lines, use wooden or fiberglass ladders instead of metal.
  - Never place a ladder where it can fall into a power line.
  - When carrying ladders, augers, or other tools, look up to make sure contact with overhead lines is avoided.
- Never try to move an electric line.
  - Don't attempt to raise or move power lines. Call your utility for assistance.
  - If you see a downed power line, call the utility immediately. Don't go near it.
- Check out your equipment.
  - Keep all electrical appliances a safe distance away from water.
  - Power tools should be properly grounded. Use only heavy duty extension cords rated specifically for outdoor use.
  - Outdoor electrical outlets should have ground-fault circuit interrupter protection and have weatherproof covers.
- If you are driving a tractor or other vehicle that comes in contact with an electric line...
  - Try to back away from the line.
  - If you are unable to back away, stay put!
  - Have someone call your local utility to de-energize the line.
  - If you must leave the tractor, jump clear, putting both feet forward at once, and avoid any contact with the ground and the vehicle at the same time.

Our #1 priority is providing you with safe and reliable electric service.

## Guidelines for Grain Bin Safety

From your Locally-Owned Municipal Electric Utility

# LOCAL Perks



POET

POET

At POET, we believe in cultivating communities and growing the local economy. We have been using biotechnology to create sustainable solutions from local agricultural products for 35 years – ensuring that rural farm families can continue to do what they love for generations to come.  
[poet.com/fairbank](http://poet.com/fairbank)

# MEDICARE QUESTIONS?

I CAN HELP!



Call me, your **LOCAL** Expert!  
 it's almost . . . **OPEN ENROLLMENT!**

Review or change your plan from October 15th to December 7th

**Amy Rechkemmer**

319-635-2526 | amy@vandaeleins.com

**VanDaele Insurance**

119 E Main St. Fairbank, IA

Call or E-mail me, I'll help answer all your health insurance plan questions!

"Currently we represent 9 organizations which offer 29 products in your area. You can always contact Medicare.gov, 1-800-MEDICARE, or your local State Health Insurance Programs for help with plan choices."

**TOWN & COUNTRY**  
 REAL ESTATE

(563) 578-8899  
 215 N. Railroad, Sumner

[www.towncountryhome.com](http://www.towncountryhome.com)  
 Serving NE Iowa

Scan here to view our current listings

Our team is happy to get working for you.



Connie Rochford  
 (319)231-9004  
 Broker



Gary Geuther  
 (319)415-9874  
 Agent



Louie Hartman  
 (319)239-0533  
 Agent



Chris Tibbott  
 (319)404-9435  
 Agent

I can't believe it is already almost Labor Day!

Fall is my favorite time of year – I hate to see summer go, but there is nothing quite like football and sweatshirts and harvest sunsets! If we blink it will soon be time to combine the crops, dress up for Halloween, and wrap up for cooler temperatures. Be sure to soak in these last few weeks of warm temperatures!

The rest of the world has been all over the place since I've last written. An assassination attempt, a Presidential Nominee dropout, CrowdStrike updates putting us all on pause. Just a few days go by and some of the largest historical headlines are quickly pushed out of the way with something even more shocking and unpredictable.

Large swings in sentiment can often spark emotional decision making amongst investors. Our job as advisors is sometimes largely reliant on our understanding of human behavior mixed with a little bit of data and math. I might field a call from a client in the morning asking me if we should go to cash because the world is going to burn – then answer a separate call from a different client in the afternoon saying “take more cash and invest it, I think it's going up from here”.

This is why, when we build plans, we purposely stress test them against major life and world events. We want you to feel confident in financial decision making no matter what the temperature of the world is.

Having a custom visual forecast helps our clients make educated decisions and they appreciate the ability to consolidate their assets into one simple log-in with toggles for decision making scenarios.



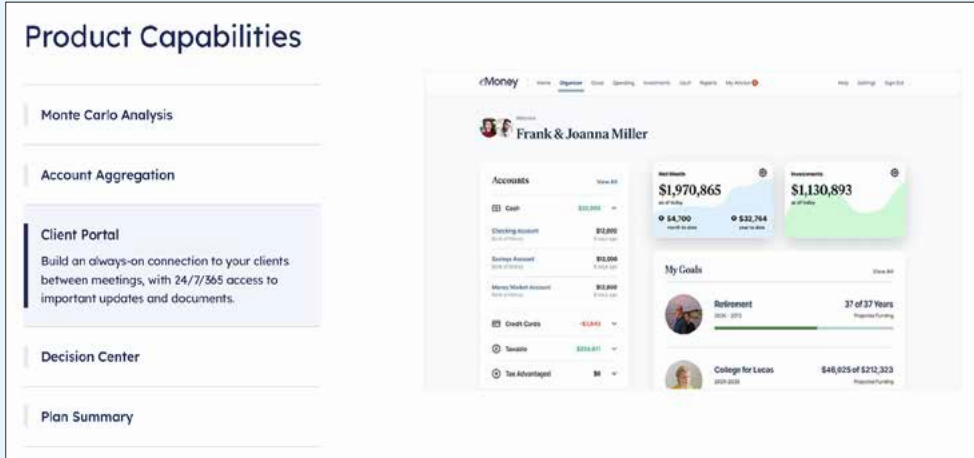

- *Should you pay for that new car in cash? Or should you stay invested and take out a loan instead?*
- *Should you try to time the market or stay invested in the highs and the lows?*
- *Should you start to draw Social Security at 62 or wait until full benefits age?*

Remember, no matter which news channel you watch or which podcast you listen to, nobody knows what the heck is going to happen tomorrow. That is why we find that financial literacy is the heart that beats behind what we do. We have to understand each client's unique situation and bring value above what they can do on their own. We prefer to lead our client meetings with financial planning so when life changes or the world changes, we can use math, data, and client sentiment to navigate the best path forward.

You've worked your butt off for what you have and you should feel confident in your plan so you can enjoy the things *you want to do* without feeling like you have to react to every headline. Let us help!

Ashlea (Kleitsch) Jones

Financial Advisor  
Prime Capital Investment Advisors  
Cedar Rapids, Iowa  
pciacedarrapids.com  
(319) 269-7143

# Fairbank Public Library



**LIBRARY STAFF**  
 Angela Berg, Director  
 Susan Frost, Librarian  
 Therese Steggall, Librarian  
 Erin Hill, Librarian  
 Roxie Wenner, Custodian

212 E. Main Street, P.O. Box 426, Fairbank, IA 50629  
 Phone: 319-635-2487 Fax: 319-635-2487  
 Email: [library@fairbank-ia.org](mailto:library@fairbank-ia.org) Website: [Fairbank-ia.org](http://Fairbank-ia.org)  
 Like us on Facebook!

Monday 1-5 pm  
 Tuesday 1-5 pm;  
 Wednesday 9 -11 am  
 1-5 pm  
 Thursday 1-6 pm  
 Friday 1-5 pm  
 Saturday 9-12



**FAIRBANK PUBLIC LIBRARY**  
**FALL BOOKSALE!**  
 THURSDAY, SEPTEMBER 26TH -  
 SATURDAY, OCTOBER 5TH!  
**FREE WILL DONATIONS!**

**Taking Book Donation  
 Now until September 25th!**

**FAIRBANK PUBLIC LIBRARY**  
**GIFT BASKET FUNDRAISER**  
 TUESDAY, NOVEMBER 12TH -  
 THURSDAY, DECEMBER 12TH 5PM!  
**BASKET DONATIONS NEEDED**

OUR SILENT AUCTION IS BACK, STOP IN AND BID ON GIFT BASKETS AFTER NOVEMBER 12TH! BASKETS WILL BE ON DISPLAY AT THE COMMUNITY CLUB'S VENDOR FAIR ON THURSDAY, NOVEMBER 14TH FROM 5-9PM. ALL BASKET ITEMS ARE DONATED BY OUR LOCAL COMMUNITY; ALL PROCEEDS BENEFIT THE FAIRBANK PUBLIC LIBRARY!  
 QUESTIONS? PLEASE CALL 319-635-2487

**In Loving Memory**

**George W. Copenhaver**  
*I Wonder Why Leaves Change Color* .....from Adam, Julie, Sylvia & Weston Costello  
**Shirley Gilliam**  
*Be You* ..... from John & Sue Frost  
*The Box Turtle* ..... from John & Sue Frost  
**George Steinbronn**  
*The Big Squeeze*..... from John & Sue Frost  
**Dennis Farrington**  
*Pete the Cat Screams For Ice Cream* ..... from The Fairbank Library & Staff  
**A New Green Day** ..... from The Fairbank Library & Staff  
*How Do you See the World?* ..... from The Fairbank Library & Staff  
**Anonymoose** ..... from The Fairbank Library & Staff  
*Hard To Kill* ..... from Gary Fink  
*The Lost Coast* ..... from John & Sue Frost  
*Shadow of Doubt*..... from John & Sue Frost  
**One Big Happy Family** ..... from Layton & Karen Tiedt  
*The Yellow Bus* ..... from Monica Siggelkov  
*The Beautiful People* ..... from Rick & Jeanette Jones  
*A Novel Summer* ..... from Rick & Cindy Woods  
**It's Not Easy Being A GHOST!** ..... from Rob & Sharon Maricle  
**Summer at The Saint** ..... from Thomas & Jane Shea  
*Mountain of Fire* ..from Joe & Marilyn Helmuth  
*Mindful Moves* ..... from Joe & Marilyn Helmuth  
*Calder Country* ..... from Thomas & Shea Shea  
*The Mosquito Burrito* ..... from Bob & Pam Byersdorfer  
**Salamander Sky** ..... from Bob & Pam Byersdorfer  
*Sour Apple* ..... from Bob & Pam Byersdorfer  
**The Wheels on the Bus at Halloween** ..... from Adam, Julie, Sylvia & Weston Costello  
**Donna Mae Geary**  
**Miranda and the Miner** ..... from Adam, Julie, Sylvia & Weston Costello  
**Mary Lou Dimmich**  
**Everything We Never Knew** ..... from Adam, Julie, Sylvia & Weston Costello

**FPL FAIRBANK PUBLIC LIBRARY**  
**CHECK OUT YOUR LIBRARY**  
**CHECK OUT AUDIOBOOKS**  
 CHECK OUT EBOOKS  
 CHECK OUT MAGAZINES  
 CHECK OUT BIKES  
 CHECK OUT MUCH MORE  
 Embark on a journey to discover everything your library has to offer  
 For more visit [yourlibrarywebsite.com](http://yourlibrarywebsite.com)

Contact the Library to check out an internet hotspot! Please let us know if you would like more information on this!

**Butterfly Release at Story Hour**

**August Library Fun!**

August 7th Michael Mass, Naturalist from Fontana Park, held our last Creature Feature Program of the summer and brought us a caterpillar that we were able to watch turn into a monarch butterfly.

We also partnered with the other Libraries in Buchanan County to put on a Foam Party!

**MONETARY DONATIONS**

Debra & Dean Brase	Arnola Siggelkov
Susan Curry Boyens	Ted & Jan Vorwald
James Tafolla	Paula Farrington

**Thank You**

**New Books Added In August!**

**B & K AUTOMOTIVE**  
 Complete Auto Repair  
**(319) 635-2058**  
 101 6th Street  
 P.O. Box 252  
 Fairbank, IA 50629  
 Serving the Community for 26+ Years!

DR. NATHAN STEINBRONN, DC  
**FAIRBANK CHIROPRACTIC**  
 101 South 4th Street  
 Suite C  
 Fairbank, IA 50629  
 319-849-5155  
[Steinbronndc@gmail.com](mailto:Steinbronndc@gmail.com)  
 CREATE YOUR BETTER TOMORROW

**COSTA'S**  
 SPORTS BAR & GRILL  
 Beni Rushiti  
 Nita Nuhiji  
 (319) 635-2449  
 99 East Main Street  
 Fairbank, Iowa 50629

## SPORTS &amp; RECREATION

## Wapsie Valley Cross-Country

BY GIDAL KAISER

sports@oelweindailyregister.com

For your information

Head coach: Justin Davie (Seventh year)

2023: Boys (Sixth SQM, eighth North Iowa Cedar League). Girls (Third SQM, eighth North Iowa Cedar League).

Key returnees

Boys: Aidan Brady, Soph.; Hayden Hilsenbeck, Jr.; Finn Schaefer, Jr.; Robert Lee, Sr.; Dallas Tisue, Sr.; Hayden Szurley, Sr.; Eric Bryan, Jr.; Marshall Weepie, Jr.; Elijah Eike, Jr.; Madden Kane, Jr.; Cameron Szurley, Jr.

Girls: Maya Barnes Jr.; Jaylin May, Sr.; Ava Meyer, Soph.; Adelynn Wierck, Jr.; Lydia Stuber, Sr.; Miriam Rulapaugh, Jr.; Austin Franck, Jr.; Maleena Sander, Jr.; Mae Wedemeier, Jr.; Haley Stuber, Jr.; Ava Meyer, Soph.

Newcomers

Boys: Jack Brodigan, Fr.; Oliver Tiedt, Fr.; Bailey Szurley, Fr.; Daniel Matthias, Fr.; Jace Heasley-Eike, Fr.

Girls: Brinley Boehme, Fr.; Adalynn Kane, Fr.; Mira Behnke, Fr.; Ella Morarend, Soph.

What They're Saying

Boys

"After having the kind of track season I had, and the top four athletes from last year's state meet either moving up a class or graduating, there is only one goal for myself coming into this year and that is winning a state title." — Aidan Brady

"The numbers look great again, and we look to have over 15 boys out this year and field two teams again. Aidan Brady brings back state experience and Finn Schaefer has been a regular in the varsity lineup since his freshman year.

"The program took a big step last season in qualifying two runners for state and finishing sixth in a very tough district. Many younger runners took huge steps last year, and if they can take another jump, the boys team looks to be very competitive.

"As school starts and our numbers grow, hey, we could snag a few extra guys that take the team from competitive to pretty darn good. We return a lot of runners but will still be a pretty young team, and we will need to develop more leadership as the season goes on." — Coach Justin Davie

Girls

"I think our girls team is going to make huge strides this year because of all the work we put in this summer. If you look at how much we've run (during summer) in the past few years compared to this year, the difference is pretty big and that shows how the teammates and athletes have changed the cross-country environment and (their) views on the sport." — Maya Barnes

"I feel like our team has a good chance to show up and prove what we



GIDAL KAISER | OELWEIN DAILY REGISTER

The 2024 Wapsie Valley girls cross-country team is, from left: Front row, Adelynn Wierck, Ella Morarend, Ava Meyer, Jaylin May, Lydia Stuber and Austin Franck. Second row, Mira Behnke, Haley Stuber, Emily Trueg, Meleena Sander, Brinley Boehme, Addalyn Kane and Maya Barnes. Not pictured: Miriam Rulapaugh, Mae Wedemeier.



GIDAL KAISER | OELWEIN DAILY REGISTER

The 2024 Wapsie Valley boys cross-country team is, from left: Front row, Bailey Szurley, Hayden Szurley, Madden Kane, Marshall Weepie, Aidan Brady and Daniel Matthias. Second row, Cameron Szurley, Jace Eike, Oliver Tiedt, Eric Bryan, Hayden Hilsenbeck and Elijah Eike.

can do. Our team is full of hard working, dedicated and strong people. I'm confident my teammates will push themselves to strive and succeed as well as encourage and help build confidence in everyone else on the team." — Adelynn Wierck

"The girls team also looks to have 15-plus girls out and field teams at

both levels. The girls program has become very consistent placing in the top four at districts for the past four years and top three in the past three years.

"This year's team returns five of our top six runners from a district team that finished third to North Linn and Beckman, two of the top teams in IA

last year (Jaylin May, Adelynn Wierck, Maya Barnes, Maleena Sander, Ava Meyer).

"Bolstered by a talented freshman class, this year's squad is one to watch out for as they start the year ranked 20th." — Coach Justin Davie





**FINANCIAL DECISIONS GROUP**  
SINCE 1960  
YOUR INSURANCE & FINANCIAL PROFESSIONALS

903 N. Frederick Avenue, Oelwein IA 50662  
(319) 283-1514 | cell (319) 440-2868  
(877) 370-6345 | fax (319) 283-1557  
nwillkinson@fdg.net | www.fdguelwein.net

**Neil Wilkinson**  
MSFS, ChFC, CLU  
Investment Adviser Representative

Securities and investment advisory services offered through Royal Alliance Associates, Inc. (RAA), member FINRA/SIPC. RAA is separately owned and other entities and/or marketing names, products or services referenced here are independent of RAA.

Live for Today. Plan for Tomorrow.

**MYERS POLARIS INC.**  
Sales, Parts and Service for UTV/ATV and Snowmobiles

**POLARIS**

304 E. Main Street  
Fairbank, IA 50629  
**319-635-2311**  
www.myerspolaris.com

**TYLER WOODS**, Sales Manager



**F.A.B. BUILDERS LLC**  
Bonded & Insured for your Protection

**SPECIALIZING IN METAL ROOFING SIDING • DECKS • REMODELING**

**FREEMAN SCHWARTZ**  
Free Estimates 1340 Fairbank Amish Blvd.  
319.238.9751 Hazelton, IA 50641

The "What" Berry Farm?  
... **Aronia Berry! LLC**  
FAIRBANK, IA

Dean & Donna Mangrich OWNERS

**Frozen Aronia Berries**

Call: 319-240-4104 or 319-240-5627



**NSB**  
NORTHEAST SECURITY BANK

Planting Dreams. Growing Success.

MEMBER FDIC

120 Main St | Fairbank | 319-635-2811  
WWW.BANKNSB.COM

**HIS HANDS FOOD PANTRY**  
5002 Main Street  
Oran, Iowa

We Serve the following communities:  
Denver, Fairbank, Fredericka, Maynard, Oran, Randalia, Readlyn, Sumner, Tripoli, Westgate

Brief application required. HOURS:  
Tuesdays 5-8 P.M.  
Fridays 9 A.M. – 12 Noon

**319-638-4357**



**DHK Welding Inc.**  
563.608.1400 Fairbank, Ia

Stainless and Aluminum Repair / Machining /  
CNC Plasma Cutting / Sandblasting /  
Powder Coating / Portable Welding

**Fairbank Historical Society**  
103 East Main Street  
Meetings held the 4<sup>th</sup> Tuesday each month  
~ Everyone Welcome ~  
Open by Appointment  
For information, call: 319-269-6795



Energizing Caffeinated Tea-Bombs  
Healthy & Delicious Meal Replacement Shakes  
Caffeine Free & Kids Options

**Balanced Nutrition**

Serving the community  
1 tasty drink at a time :)

319-635-8012 119 East Main Street  
Fairbank, IA 50629



**WOODS CONSTRUCTION INC.**  
FAIRBANK, IA.

"Serving Fairbank & the surrounding area since 1967"

Offering a diverse portfolio of services:

- ▶ New Home Construction & Design
- ▶ Remodeling & Additions
- ▶ Light Commercial Buildings
- ▶ Agricultural Buildings
- ▶ Earth Moving







Visit our website or give us a call to schedule a consultation!  
505 2<sup>nd</sup> St. NE • Woodsconst.com • 319-635-2308





**DAVIS LAWN SERVICE**  
FAIRBANK, IOWA  
319-239-5011

**We offer:**

- \* Weed Control
- \* Fertilization
- \* Lawn Mowing
- \* Core Aeration
- \* Grub Preventer
- \* Spring & Fall Cleanups
- ... and much more!

*Knowledgeable and helpful.  
Locally owned and operated.*

FAIRBANK, IOWA



**FAIRBANK Food Center** We're Proud To Serve You!

Your Local Full Service Grocery Store

**We Offer Catering**

- ♦ Weddings ♦ Birthdays
- ♦ Graduations ♦ Retirement Parties

Fresh Meat and Produce  
Dairy ~ Frozen ~ Grocery

**Fairbank Deli - Best Around**

- ♦ Delicious Dinners ♦ Broasted Chicken
- ♦ Succulent Salads ♦ Sandwich Fillings
- ♦ Party Trays (meat, cheese, veggie, fruit)
- ♦ Sandwiches ♦ Soup ♦ Entrees ♦ Desserts

102 N. 4<sup>th</sup> St., Fairbank, IA ~ 319-635-2139  
Open: 7:30am - 7:00pm M-F; 7:30am - 6:00pm S&S  
Check Out Our Complete Ad at [fairbankfoodcenter.com](http://fairbankfoodcenter.com)

# You want the TV you love with personal service you can trust.

## We hear you.

That's why at Schmidtke Video Systems, we take the time to listen to your needs and get you the right entertainment solutions. We're close to home, a familiar face and offer the best service, value and technology for you and your family.

Plus, ask about our whole-home HD DVR solution to power your entire home.



**DUANE SCHMITDKE, OWNER**

**190 CHANNELS**

AMERICA'S TOP 120  
All-Time Favorites and Locals



Plus More!

Control your TV and Smart Home with your voice.

Turn on ESPN

Dim the living room lights



Enjoy built-in Amazon Prime Video, Netflix, YouTube and more.



Get total recording freedom with 2,000 hours of DVR storage.



Requires internet-connected Hopper, Joey, or Wally device. Customer must press Voice Remote button to activate feature. Netflix and Amazon Prime Video streaming memberships required. YouTube is a trademark of Google LLC. Recording hours may vary; 2,000 hours based on SD programming



**Schmidtke Video Systems | 319-319-4749**  
303 N. Water St., Fairbank, IA 50629  
[northeastiowasatellite.getdish.com](http://northeastiowasatellite.getdish.com)



Offer for new and qualifying former customers only. Important Terms and Conditions: **2-year commitment:** Early termination fee of \$20/mo. remaining applies if you cancel early. **Regional Sports:** RSN surcharge up to \$3/mo. applies to AT120+ and higher packages and varies based on location. **NOT included in 2-year price guarantee or advertised price (and subject to change):** Taxes & surcharges, add-on programming (including premium channels), DISH Protectand transactional fees. **Premium Channels:** 3 Mos. Free: After 3 mos., you will be billed \$30/mo. for Showtime, Starzand DISH Movie Pack unless you call or go online to cancel. **Remote:** The DISH Voice Remote with Google Assistant requires internet-connected Hopper, Joey or Wally device. Customer must press Voice Remote button to activate feature. Google Assistant Smart Home features require Google account and compatible devices. Google is a trademark of Google LLC. **Other:** All packages, programming, featuresand functionality and all prices and fees not included in price guarantee are subject to change without notice. After 6 mos., if selected, you will be billed \$9.99/mo. for DISH Protect Silver unless you call to cancel. After 2 years, then-current everyday prices for all services apply. For business customers, additional monthly fees may apply. Free standard professional installation only.



# FAIRBANK FIRE AND EMS ASSOCIATION NEWS

Was an incredible day providing our local Amish Community with valuable safety, health and wellness information. Over 300 individuals gained knowledge and training in various areas including hands only CPR, Stop The Bleed, first aid, BP checks, pedestrian safety, fire extinguisher use, gun & water safety, water quality and car seat use. Day was highlighted with a fly in by the AirCare

helicopter. Huge thank you goes out to the following agencies: Buchanan County Public Health Buchanan County Emergency Management Buchanan County Health Center Benton County Public Health Buchanan County Environmental Health Iowa DNR AirCare Hazelton Fire Department Dunkerton Ambulance Service and Fairbank Fire Department



## Beck joins EMT crew



Congratulations to Jenna Beck our newest EMT. Jenna recently completed her EMT class passing her skills and written tests. Jenna will be a great addition to our crew.

**FAIRBANK FIRE & EMS ASSOCIATION**  
**SPAGHETTI SUPPER**  
**& R3 TRAILER OPEN HOUSE!**

FAIRBANK FIRE STATION  
 301 GROVE ST, FAIRBANK, IA 50629

**SATURDAY, SEPTEMBER 21ST**  
**4:00-7:00 PM**

**MENU**  
 SPAGHETTI (MARINARA & ALFREDO)  
 BREADSTICKS  
 DESSERTS  
 BEVERAGES

COME CHECK OUT THE FIRST RURAL RESCUE RESPONSE TRAILER IN IOWA!

**- FREE WILL DONATION -**

**Oran Fire & EMS**

**UTV POKER RUN**

**SATURDAY SEPTEMBER 14**

**STARTS & FINISH AT ORAN FIRE DEPARTMENT STEAK FRY TO FOLLOW**

REGISTRATION BEGINS AT 8 AM AND RELEASED AT 9:45 AM STOPS AT OUTPOST, COSTAS, OUTER BANKS, LITTLETON LOUNG, FAT BOYZ SALOON, THE BANK BAR & GRILL, BENTS SMOKEHOUSE, PANTHER LANES, GRUMPY'S THE STORE STEAKS PREPARED BY ORAN LOCKER

FOR MORE INFORMATION:  
 JANICE MARTINS: 563-920-5016  
 LAYNE HILSENBECK: 563-608-1400

DONATE \$10/ PERSON  
 16 OZ RIBEYE- \$25  
 CHICKEN BREAST- \$15

THE FAIRBANK COMMUNITY CLUB IS SPONSORING:

**CITY OF FAIRBANK**

**GARAGE SALES**

BEGINS SATURDAY OCTOBER 5<sup>TH</sup> / PICK UP MONDAY OCTOBER 7<sup>TH</sup>  
 STARTING AT 8 A.M.

Interested in Signing Up?  
 Please stop by the Fairbank Library & fill out your entry form! You can also check out the Community Club Facebook Page for online registration.  
 ENTRY FORMS MUST BE RECEIVED BY OCTOBER 2ND AT 5 P.M.

Maps will be distributed to local businesses on Thursday!

**September**

**COMMUNITY POTLUCK**

BRING YOUR FAVORITE DISH!

**SEPT. 18, 2024 AT 11:30 AM**

Tableware and beverages provided.  
 Sponsored by IC Parish Life Committee.

**Shop local**

**YOUR COMMUNITY, YOUR HOME**

# NEW LISTING - ACREAGE

## 16283 50TH ST., OELWEIN



Easy Location  
1 mi N of Oelwein,  
1968 Ranch, 1,728  
sq' main + 1,10 sq'  
Bsmnt, 4 bedrms,  
3 baths, walk out  
bsmnt,  
2 car tuck under gar  
+ 36'x26' det gar.

### LIKE NEW!



824 PROSPECT  
ST., JESUP  
**\$245,000**

### NEW PRICE



730 PROSPECT  
ST., LAMONT  
**\$240,000**

### NEW PRICE



116 5TH ST. NW,  
OELWEIN  
**\$129,000**

### PENDING

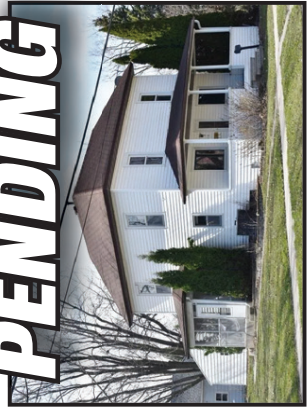

118 7TH ST. SW,  
OELWEIN  
**\$74,900**

### PENDING



40 5TH ST. NW,  
OELWEIN

### SOLD

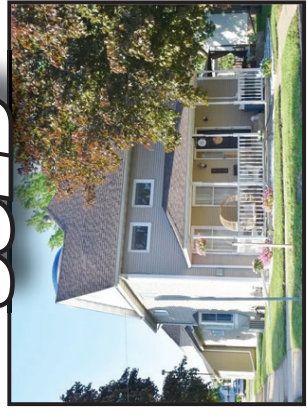

120 W. 2ND ST.,  
SUMNER

### SOLD



222 4TH AVE. NW,  
OELWEIN



117 6TH AVE.  
SE, OELWEIN  
**\$150,000**

## THINKING OF SELLING? CALL ME! I NEED LISTINGS!



# ADVANCED, REALTORS®, LLC

814 S. Frederick, Oelwein 283-2242

Lori Beierschmitt, Broker/Owner

Cell: 319-238-1700



REALTOR.COM REALTOR.COM REALTOR.COM